

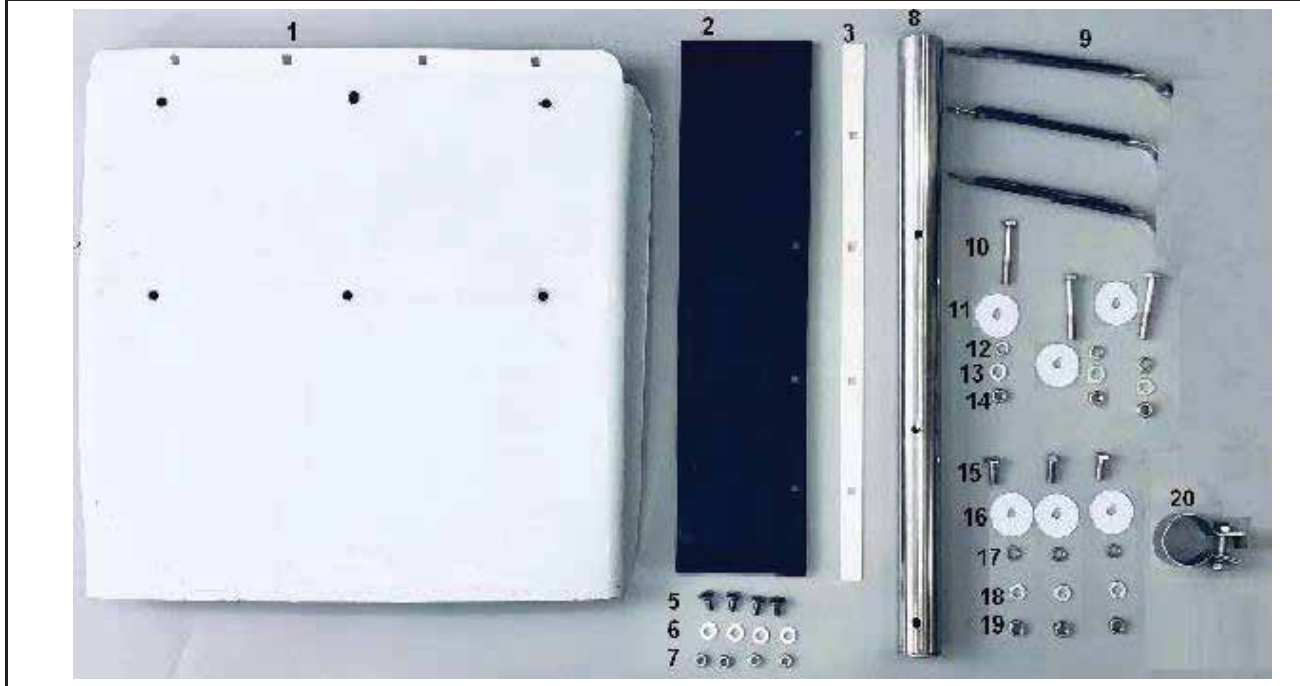

# TFEN-Q25 Installation Instructions

Trux#	Description
TFEN-Q25	OE Replacement Top Brace T430 Stainless Quarter Fender
All parts for 1 set of TFEN-Q25	



**All parts for 1 set of TFEN-Q25 in details:**

1: Shield	2: Top mud flap	3: Plate for mud flap	5: Half round top bolt
6: Flat washers	7: Nuts	8: Tube	9: Long braces
10: Long bolts	11: Big washers	12: Spring washers	13: Plate washers
14: Nuts	15: Short bolts	16: Big washers	17: Spring washers
18: Flat washers	19: Nuts	20: Clamp	
1 set of TFEN-Q25 Measurement Diagram		Step #1 Install small braces onto the tube	

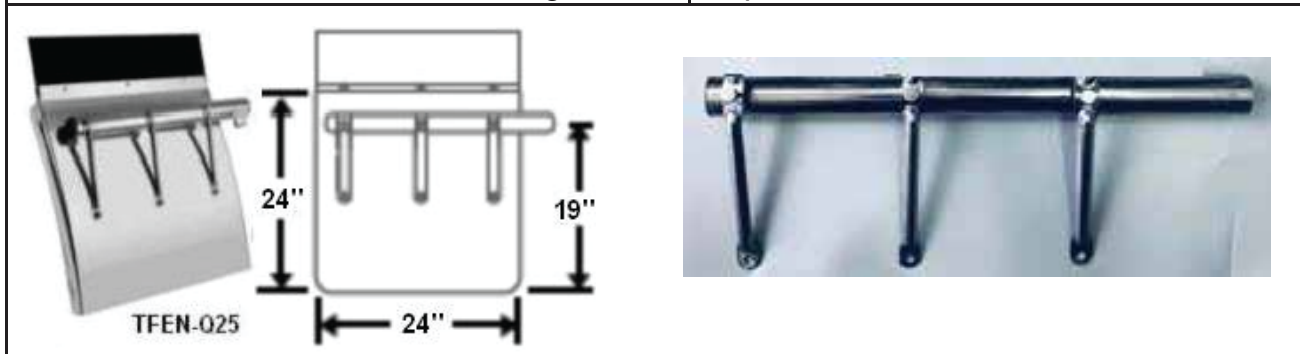



# TFEN-Q25 Installation Instructions

Trux#	Description	
TFEN-Q25	OE Replacement Top Brace T430 Stainless Quarter Fender	
<p>Step #2: Install the tube on the shield. See measurements diagram above as location reference for tube (19" above the base of shield).</p>	<p>Observe Step #2's Bolts position Use # 10-11-12-13-14 to attach top of braces to Tube Use # 15-16-17-18-19 to attach bottom of braces to Shield</p>	
	 	
<p>Step #3: Install washers and nuts</p>	<p>Step #3's flat washer, spring washer and nut position</p>	
	 	
<p>Step #4: Install top mud flap by using parts #2,3,5,6,7 and then install and clamp to the tube</p>	<p>flap nut's position</p>	
		<p>Back of mud flap</p>  <p>Front of mud flap</p> 